

Using drill presses safely

Over the past five years, 62 workers have been injured in B.C. while operating floor or bench-mounted drill presses. Most of the incidents resulted from loose clothing, inadequate safeguarding, poor set-up of the drill press and its work area, inadequate training, or inadequate lighting. This bulletin outlines potential hazards and recommends safe work practices.

Recognizing hazards

The most common hazard is loose clothing. Incidents were most often caused by workers' gloves getting caught in the drill. Other incidents were caused by long hair or loose clothing, such as coveralls or long-sleeved shirts, getting caught in a rotating drill bit.

Using safeguards

Always use appropriate safeguards when working with a drill press. Ensure the guards are in place and in good working condition. The drill press should have fixed guards or chuck shields. These are usually transparent barriers that protect workers from flying chips, coolant, sparks, swarf, and rotating parts.

Safe work practices

The following safe work practices can help you reduce your risk of injury when using a drill press.

Before starting work

- Read the manufacturer's manual to ensure you understand the proper operation of the drill press.
- Make sure you're trained in the safe work procedures for the drill press.
- Inspect the area around the drill press to ensure it's safe to operate. Keep the area clear of debris and sawdust that may cause slips, trips, and falls.

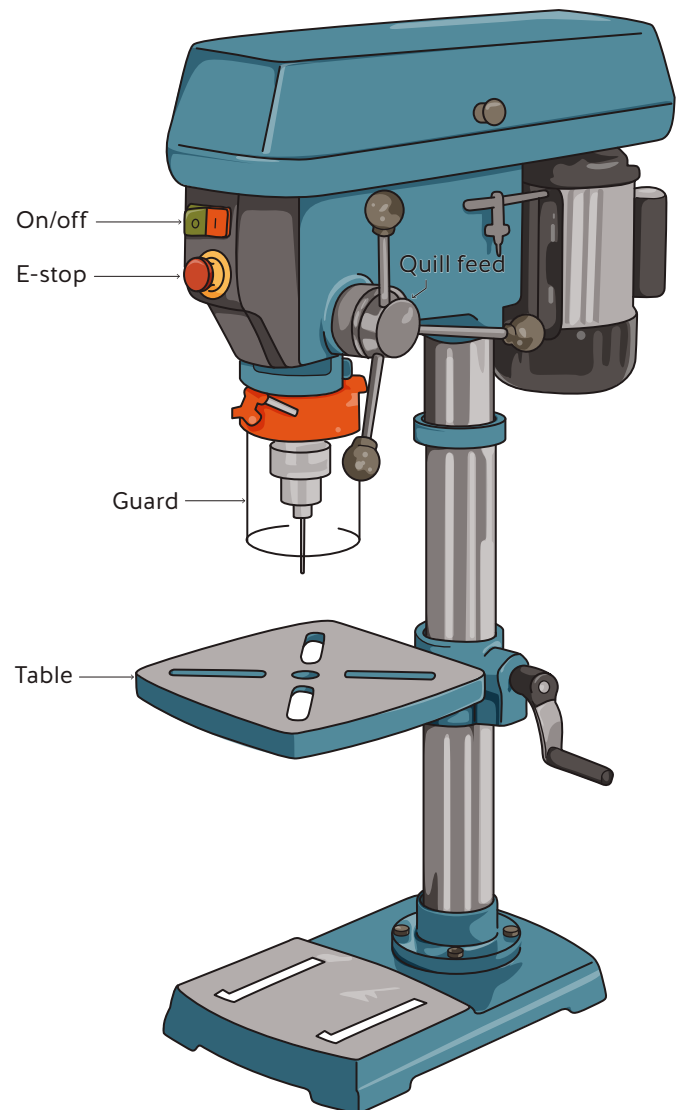

Example of a drill press.

- Review safety data sheets to identify hazardous work materials and cutting fluids.
- Tag defective equipment and remove it from service.
- Inform your supervisor of any safety concerns or damage to the drill press.
- Before starting the drill press, ensure that the critical controls are within easy reach and safeguards are in place. Critical controls include the start and stop buttons and the mushroom-shaped emergency stop button.
- Wear appropriate personal protective equipment (PPE), including safety glasses or a face shield, hearing protection, and safety shoes.
- Don't wear gloves, even tight-fitting ones. They can get caught in rotating parts.
- Avoid loose clothing. If necessary, roll up your shirt sleeves.
- Remove all jewellery, including watches.
- Tie back long hair securely.

During work

- Secure work pieces with clamps or a drill vise to prevent spinning.
- Before starting the drill press, tighten the chuck for the drill bit or cutting tool securely, and then remove the chuck key.
- Always drill a smaller pilot hole before drilling larger-diameter holes.
- Don't reach around or under a rotating drill bit.
- Make sure the size of the bit is equal to or smaller than the capacity of the drill press.
- Use appropriate speeds for the type and size of bit and the type of stock being drilled.
- Use a centre punch to punch a drill-hole location in metal stock.
- Lock out as required to remove burrs, chips, and curls with a vacuum or brush as they accumulate (and after completing work).
- Adjust lighting to illuminate the work area.
- If standing for a long time, use an anti-fatigue mat.

After completing work

- Make sure the chuck or cutting tool comes to a complete stop before doing other work in the area.
- De-energize and lock out the drill press before doing maintenance, adjusting belts, or cleaning or changing drill bits.
- Clean and put away PPE.
- Keep drill bits clean and sharp.

Regulation requirements

For requirements related to drill presses, see the following sections of the Occupational Health and Safety Regulation and its related guidelines (available on worksafebc.com):

- Section 4.3, [Safe machinery and equipment](#)
- Section 10.2, [General requirement](#) (for de-energization and lockout)
- Section 10.3, [When lockout required](#)
- Part 12, [Tools, machinery and equipment](#)

Resources

The following resources are available on worksafebc.com:

- [Safeguarding](#) (webpage)
- [Safeguarding Machinery and Equipment](#) (manual)
- [Machine Risk Assessment Survey](#)
- [Lockout & de-energization](#) (webpage)

For more information

See the following web resources for information on using drill presses safely.

From the Canadian Centre for Occupational Health and Safety:

- [Metalworking Machines — Drill Presses](#)

From Workplace Safety & Prevention Services:

- [Machine, Tools and Equipment](#)
- [Drill Press Safety Tips](#)